

## Recent developments in rock support estimates by the RMi

by Arild Palmström, Ph.D., Norway

### SUMMARY

*The RMi (rock mass index) system applies input of block size, joint characteristics and strength of intact rock to express the uniaxial compressive strength of a rock mass. From practical use in more than 5 years the RMi rock support method has been further developed. It is now more user-friendly and easier to learn. Preliminary support estimates can be made from input only of block size and the size of the tunnel when only limited knowledge of the ground conditions is available. Later, when more information of ground is available, more accurate support estimates can be made.*

*Tables and support charts are presented together with several examples. Instructions are given how to make a computer spreadsheet from which the RMi and the support parameters easily can be calculated. As for all systems for evaluating rock support an understanding of the geology of the area and knowledge of the ground conditions at site are important for proper use of the RMi.*

### 1. INTRODUCTION

The RMi (rock mass index) support method was introduced in 1995 as a result of a Ph.D. performed at the University in Oslo, Norway. It applies input of the main features influencing on rock mass properties to express the uniaxial compressive strength of rock masses. As earlier presented by Palmström (1995 and 1996), the RMi can be used in several applications in addition to its use in support estimates, such as

- characterisation of rock mass strength and rock mass deformation,
- calculation of the constants in the Hoek and Brown failure criterion for rock masses, and
- assessment of TBM penetration rate.

This paper shows important developments in the RMi rock support method after more than 5 years of practical application. The method is now more user-friendly after a few simplifications and adjustments. It is shown that only inputs of block volume and tunnel diameter are necessary for making preliminary rock support estimates. This may be useful when only limited information on the ground conditions is available, for example at an early stage of a project. Later, when the values or ratings of the input factors have been measured or observed, more accurate support estimates can be made.

Applying the 3-dimensional block volume as a main input to RMi, several benefits are achieved, both in characterising a rock mass and in rock engineering calculations. Methods to assess the block volume from various types of field measurements are shown in the Appendix.

The great benefit in using computer spreadsheets to calculate the value of RMi and the support parameters is shown together with the instruction to work out a simple spreadsheet (Excel). By this, the calculations can be quickly made, because the relevant equations and input parameters are linked in the spreadsheet. This is shown in the Appendix.

In this paper *rock* = the construction material, i.e. intact rock; *rock mass* = rock(s) penetrated by joints; and *ground* = rock mass subjected to stresses and ground water.

## 2. THE ROCK MASS INDEX (RMi)

The rock mass index is a volumetric parameter indicating the approximate uniaxial compressive strength of a rock mass. It is expressed as:

- For jointed rock:  $RMi = \sigma_c \times JP = \sigma_c \times 0.2\sqrt{jC} \times Vb^D \quad (D = 0.37 jC^{-0.2})$  eq. (1)

- For massive rock:  $RMi = \sigma_c \times f_\sigma = \sigma_c (0.05/Db)^{0.2} \approx 0.5\sigma_c$  eq. (2)

The symbols in the expressions above represent:

$\sigma_c$  = the uniaxial compressive strength of intact rock, measured on 50 mm samples. Some average strength values are given in Table A1 in the Appendix.

$jC$  = the joint condition factor, which is a combined measure for the joint size ( $jL$ ), joint roughness ( $jR$ ), and joint alteration ( $jA$ ), given as  $jC = jL \times jR/jA$  [eq. (3)] Their ratings are shown in Table 1.

$Vb$  = the block volume, measured in  $m^3$ ; the average volume is generally applied. ( $Db = \sqrt[3]{Vb}$  is the equivalent block diameter, measured in m)

$JP$  = the jointing parameter, which incorporates the main joint features in the rock mass. Its value can be found from the lower diagram in Figure 4 or from eq. (1) ( $JP = 0.2\sqrt{jC} \times Vb^D$ ).

$f_\sigma$  = the massivity parameter ( $f_\sigma = (0.05/Db)^{0.2}$ ); an adjustment for the scale effect of compressive strength in massive rock. Massive rock occurs generally when  $Db >$  approx. 2 m, for which  $f_\sigma \approx 0.5$ .

When  $JP < f_\sigma$ , (this is where  $JP <$  approx. 0.5) eq. (1) is applied. See lower diagram in Figure 4.

Figure 1 shows connection between the input parameters applied in the RMi. For the most common joint characteristics  $jC = 1.75$  which gives  $RMi = \sigma_c \times JP = \sigma_c \times 0.26 \sqrt[3]{Vb}$  (eq. 1a)

This can be used when only limited information is available on the rock mass conditions, see example 1 in Section 5.

The classification of RMi is:

Very low	$RMi < 0.01$
Low	$RMi = 0.01 - 0.1$
Medium	$RMi = 0.1 - 1$
High	$RMi = 1 - 10$
Very high	$RMi > 10$

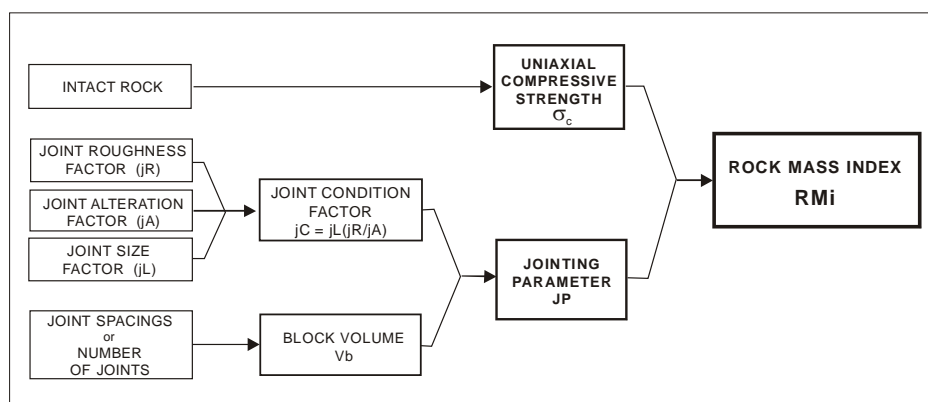

Figure 1 The input parameters to RMi

## 3. THE RMi ROCK SUPPORT METHOD

The principles in the RMi support method are shown in Figure 2. As shown in Figure 3 the number of blocks in the periphery of an underground opening will largely determine whether the surrounding ground will behave:

- 1) as a *continuous*, bulk material where the magnitude of the rock stresses is important; or
- 2) as a *blocky* material, dominated by the individual blocks and the character of the joints.

This can be assessed from the ratio  $CF = \text{tunnel diameter/block diameter}$ , which is called the *Continuity Factor*. With a markedly difference in behaviour of these two groups (see Figure 3), the RMi support method applies different calculations and support charts for continuous and blocky ground.

Table 1 The values and ratings of the input parameters to RMI.

INPUT PARAMETERS TO THE RMI						
<b>UNIAXIAL COMPRESSIVE STRENGTH, <math>\sigma_c</math></b> of intact rock		<b>value</b> (in MPa)	found from laboratory tests (or assumed from handbook tables)			
<b>BLOCK VOLUME, <math>V_b</math></b>		<b>value</b> (in $m^3$ )	measured visually at site (or estimated from borehole cores)			
<b>JOINT CONDITION FACTOR, <math>jC</math></b>		<b><math>jC = jR \times jL / jA</math></b>	ratings of $jR$ , $jA$ and $jL$ in the tables below			
<b>JOINT ROUGHNESS FACTOR (<math>jR</math>)</b> (the ratings of $jR$ are based on $J_r$ in the Q-system)						
(The ratings in <b><i>bold italic</i></b> are similar to $J_r$ )		Large scale waviness of joint plane				
		Planar	Slightly undulating	Undulating	Strongly undulating	Stepped or interlocking
Small scale smoothness of joint surface	Very rough	2	3	4	6	
	<b><i>Rough</i></b>	<b><i>1.5</i></b>	2	<b><i>3</i></b>	4.5	
	<b><i>Smooth</i></b>	<b><i>1</i></b>	1.5	<b><i>2</i></b>	3	
	Polished or <i>slickensided</i> <sup>*)</sup>	<b><i>0.5</i></b>	1	<b><i>1.5</i></b>	2	
For filled joints $jR = 1$ For irregular joints a rating of $jR = 5$ is suggested						
*) For slickensided surfaces the ratings apply to possible movement along the lineations						
<b>JOINT ALTERATION FACTOR (<math>jA</math>)</b> (the ratings of $jA$ are based on $J_a$ in the Q-system)						
Contact between joint walls	<b>JOINT WALL CHARACTER</b>		<b>Condition</b>		<b>Wall contact</b>	
	CLEAN JOINTS:	Healed or welded joints	filling of quartz, epidote, etc.		0.75	
		Fresh joint walls	no coating or filling, except from staining (rust)		1	
		Altered joint walls	- one grade higher alteration than the rock - two grades higher alteration than the rock		2 4	
	COATING or THIN FILLING OF:	Friction materials	sand, silt calcite, etc. without content of clay		3	
Cohesive materials		clay, chlorite, talc, etc.		4		
Partly or no wall contact	<b>FILLING OF:</b>	<b>Type</b>			<b>Partly wall contact</b> Thin filling (< 5 mm)	<b>No wall contact</b> Thick filling
	Friction materials	sand, silt calcite, etc. (non-softening)			4	8
	Hard, cohesive materials	compacted filling of clay, chlorite, talc, etc.			6	6 - 10
	Soft, cohesive materials	medium to low overconsolidated clay, chlorite, talc, etc.			8	12
	Swelling clay materials	filling material exhibits swelling properties			8 - 12	13 - 20
<b>THE JOINT SIZE FACTOR (<math>jL</math>)</b>						
<b>TYPE</b>	<b>Length</b>	<b>Size</b>		Continuous joints	Discont. joints <sup>*)</sup>	
Bedding or foliation partings	< 0.5 m	very short		3	6	
Joints	0.1 - 1 m	short or small		2	4	
	1 - 10 m	medium		1	2	
	10 - 30 m	long or large		0.75	1.5	
(Filled) joint, seam or shear <sup>**)</sup>	> 30 m	very long or large		0.5	1	
*) Discontinuous joints end i massive rock      **) Often a singularity and should in these cases be treated separately						

Table 2 Ratings of the adjustment factors for rock support estimates in blocky ground. Note that the factors have unit values for their most common occurrence.

ROCK SUPPORT ADJUSTMENT FACTORS							
<b>STRESS LEVEL</b>	Approximate overburden	Rating SL	<b>NUMBER OF JOINT SETS <sup>*)</sup></b>	Rating Nj	<b>NUMBER OF JOINT SETS <sup>*)</sup></b>	Rating Nj	
Very low (in portals, etc.)	< 10 m	0.1	One set	3	Three sets	1	
Low	10 - 35 m	0.5	One set + random	2	Three sets + random	0.85	
Moderate	35 - 350 m	1	Two sets	1.5	Four sets	0.75	
High	> 350 m	1.5 <sup>*)</sup>	Two sets + random	1.2	Four sets + random	0.65	
*) For stability in high walls a high stress level may be unfavourable. Possible rating SL = 0.5 - 0.75			*) Means the number of joint sets at the actual location (Not the number of joint sets observed in a larger area)				
<b>ORIENTATION OF JOINTS</b> (related to the axis of the tunnel)				Rating $C_o$ and $C_o_s$	<b>INCLINATION OF ROOF or WALLS</b>		Rating $C$
<b>IN WALL</b>		<b>IN ROOF</b>	<b>TERM</b>				
for strike > 30°	for strike < 30°	for all strikes					
dip < 30°	dip < 20°	dip > 60°	favourable	1	Horizontal (roof)	1	
dip = 30 - 60°	dip = 20 - 45°	dip = 45 - 60°	fair	1.5	30° inclination	1.5	
dip > 60°	dip = 45 - 60°	dip = 20 - 45°	unfavourable	2	45° inclination	2.2	
-	dip > 60°	dip < 20°	very unfavourable	3	60° inclination	3	
					Vertical (walls)	5	

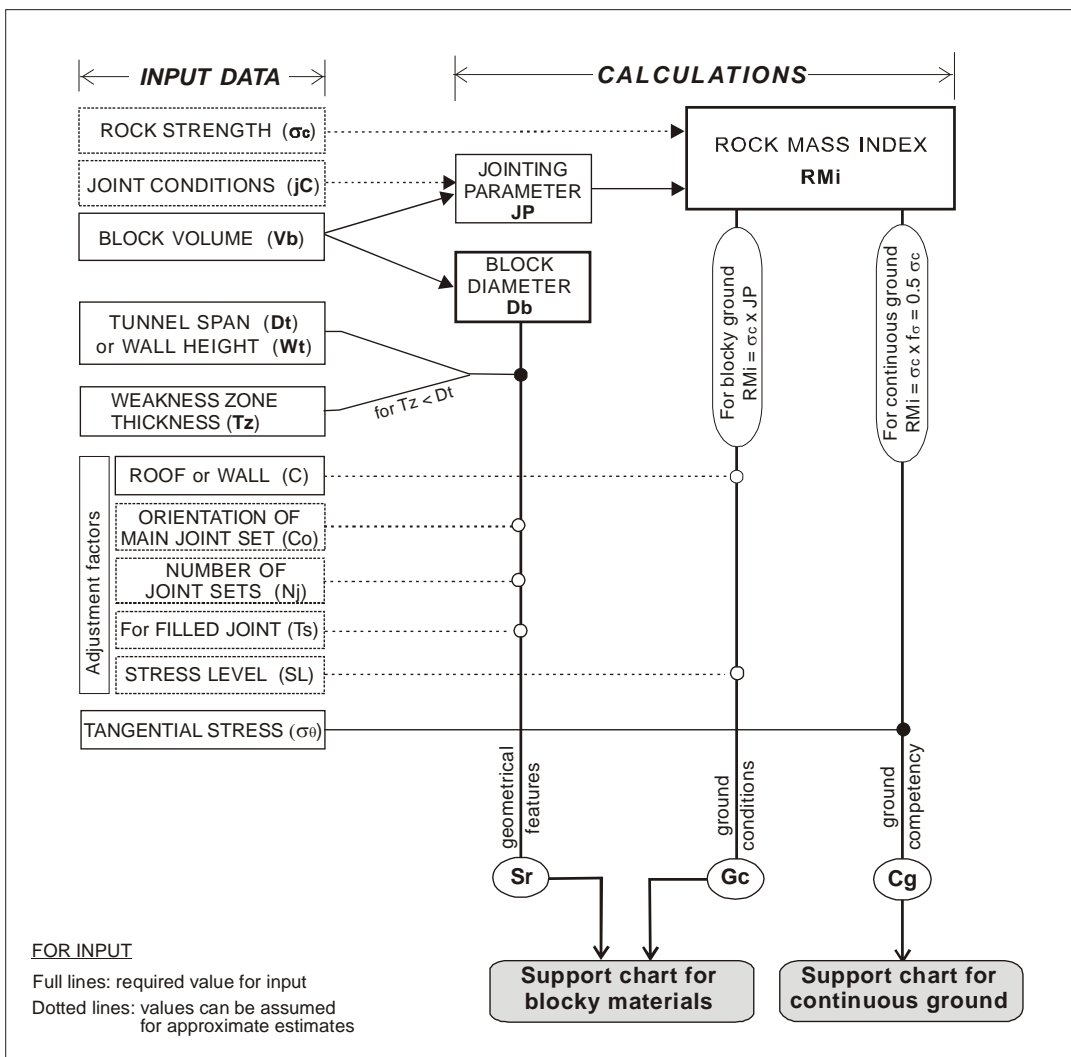

Figure 2 The input data and their use in the RMI rock support system

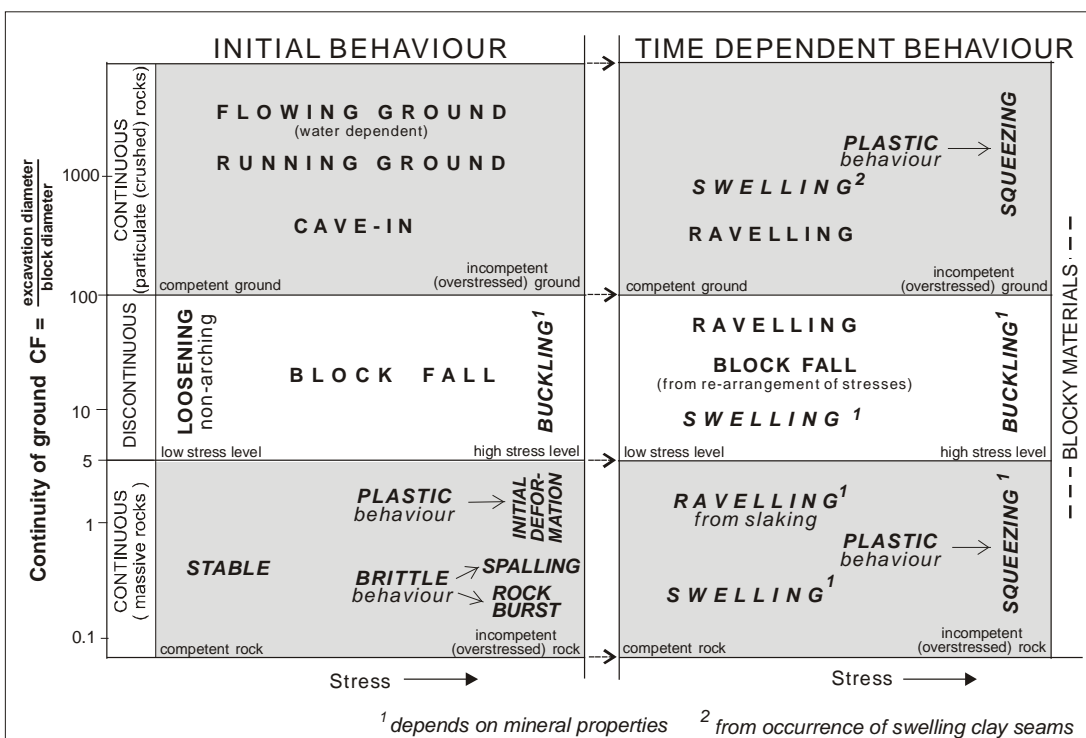

Figure 3 Instability and rock mass behaviour, determined by the stress conditions and the continuity of the ground (i.e., the number of blocks in the tunnel periphery)

### 3.1 Blocky ground

The stability in blocky (jointed) ground is mainly influenced by the block size and shape, the shear strength of the joints delineating the blocks, and the orientation of the same joints relative to the opening. The following two support parameters, which include all these features, are used in the support chart in Figure 4:

- The ground quality, given as the *ground condition factor*

$$G_c = R_{Mi} \times (SL \times C) = \sigma_c \times JP \times (SL \times C) \quad \text{eq. (4)}$$

- The scale factor, expressed as the *size ratio*

$$S_r = CF \times (C_o / N_j) = (D_t / D_b) \times (C_o / N_j) \quad \text{eq. (5)}$$

Here  $D_t$  = The diameter or span of the tunnel or cavern, in metre. (For walls, the height  $W_t$  is used instead of  $D_t$ ).

$D_b$  = The equivalent block diameter<sup>1</sup>  $D_b = \sqrt[3]{V_b}$  (in metre).

$C$  = A gravity adjustment factor for support in the roof or in the walls. Its ratings depend on the inclination of the walls and roof, and can be found from Table 2 or from the expression  $C = 5 - 4 \cos \delta$  where  $\delta$  = angle (dip) of the opening surface measured from horizontal.

$SL$  = A stress level adjustment, see Table 2.

$C_o, C_{o_s}$  = An adjustment factor for the main joint set, or seam, respectively, see Table 2.

$N_j$  = An adjustment factor for the number of joint sets; and hence the freedom for the blocks to fall. Its ratings in Table 2 can also be found from  $N_j = 3/n_j$  where  $n_j$  = the number of joint sets.  
( $n_j = 1$  for one set;  $n_j = 1.5$  for one set plus random joints;  $n_j = 2$  for two sets,  $n_j = 2.5$  for two sets plus random joints; etc.)

$T_z$  = Thickness of the weakness zone in eq. (7).

The ratings in Table 2 of the adjustment factors  $SL, C, C_o,$  and  $N_j$  have unit value for their most common or typical conditions. Thus eqs. (4) and (5) can be expressed as

$$G_c = \sigma_c \times JP \quad \text{and} \quad S_r = D_t / D_b.$$

When the value of these factors are measured or known, more accurate calculations can be made, as illustrated in Section 5.

In cases where a *seam* or *filled joint* (with thickness  $T_s < 1$  m) occurs in the location, the following adjustment of the size ratio may be made:

$$S_{r_s} = S_r (1 + T_s) C_{o_s} \quad \text{eq. (6)}$$

*Weakness zones* should in many cases be treated individually without using support or classification systems. Support assessments for crushed zones with blocky materials (where  $CF = \text{approx. } 1 \text{ to } 600$ ) may, however, be carried out using the support chart for blocky ground in Figure 4 and input parameters as for blocky ground. In small and medium sized zones (thickness between 1 and approximately 20 m) stability is influenced by the interplay between the zone and the adjacent rock masses. Therefore, the stresses in such zones are generally lower than in the adjacent ground, which will reduce the effect of squeezing.

The ground condition factor ( $G_c$ ) is the same as for blocky ground, while the size ratio for weakness zones is

$$S_r = (T_z / D_b)(C_o / N_j) \quad \text{for } T_z < D_t \quad \text{eq. (7)}$$

$$S_r = (D_t / D_b)(C_o / N_j) \quad \text{for } T_z > D_t \quad (\text{which is similar to eq. (5)})$$

For zones with  $CF > 600$  special rock support evaluations should generally be made. Large zones (thickness  $T_z > \text{approx. } 20$  m) will often behave similar to continuous ground described in Section 3.2 as there will be little or no arching effect.

<sup>1</sup> In earlier RMI publications the expression for  $D_b$  has been adjusted for the block shape, (the  $\beta$  factor, see Appendix). As experience has shown that this adjustment in most cases does not give more accurate results the expression for  $D_b$  has been changed. The Y-axis in the support chart in Figure 4 has been adjusted to compensate for this change.

For crushed weakness zones some typical RMI values for the most common conditions have been given in Table 3. They may be used for estimates at an early stage of a project or for cases where the composition of the zone is not known, see examples 2 and 4 in Section 5. The approximate RMI<sub>z</sub> values are based on assumed representative block volumes for the various types of zones

Table 3 Typical values of the rock mass index (RMI<sub>z</sub>) used for various types of crushed zones

Crushed zones	Average uniaxial compressive strength	Average joint condition factor	Approximate block size		Approximate typical value
	$\sigma_c$ (MPa)	<b>jC</b>	volume	diameter	
	<u>of the rock blocks</u>		<b>Vb</b> ( m <sup>3</sup> )	<b>Db</b> ( m )	<b>RMI<sub>z</sub></b>
Coarse fragmented zones	100	0.5	0.01	0.2	2
Small fragmented zones	100	0.5	0.0001	0.05	0.3
Clay-rich (simple) zones	80	0.1	0.01	0.2	0.3
Clay-rich (complex) zones	40	0.1	0.001	0.1	0.03
	<u>of the clay material</u>				
Clay zones*	0.1	-	1 cm <sup>3</sup> (nom.)	0.01	0.05

\* For zones containing mainly clay, approximate support estimates may be carried out using a nominal minimum block volume of Vb = 1 cm<sup>3</sup>

### 3.2 Continuous ground

*Continuous ground* occurs when CF < approx. 5 (*massive rock*), in which the properties of intact rock dominate, and when CF > approx. 100 (*particulate or highly jointed rock*), where the ground behaves as a bulk material. In these types of ground the main influence on the behaviour in an underground opening comes from the stresses. Therefore, a competency factor (Cg = strength of the rock mass/stresses acting) is used. It is expressed as:

- In massive ground  $C_g = RMI / \sigma_\theta = f_\sigma \times \sigma_c / \sigma_\theta \approx 0.5 \frac{\sigma_c}{\sigma_\theta}$  (eq. 8)

- In particulate ground  $C_g = RMI / \sigma_\theta = JP \frac{\sigma_c}{\sigma_\theta}$  (eq. 9)

Here  $\sigma_\theta$  = the tangential stress in the rock masses around the opening. A method to estimate  $\sigma_\theta$  in roof and walls of a tunnel in massive rock is shown in the Appendix.

Competent ground occurs where  $C_g > 1$ ; else the ground is overstressed (incompetent).  $C_g$  is applied in the ground support chart (Figure 5).

*Massive*, competent ground is generally stable, see Figure 3, and does generally not need any support, except for some scaling work in drill & blast tunnels. *Massive, incompetent* (overstressed) ground, however, requires support because the following time-dependent types of deformation and/or failures may take place:

- *squeezing* in overstressed ductile rocks (such as schists);
- *spalling* or *rock burst* in overstressed brittle, hard rocks (such as granite and gneiss).

*Particulate* materials (highly jointed rocks) require generally immediate support. Their initial behaviour is often similar to that of blocky ground, i.e. the support chart in Figure 4 can be used for CF = 1 to 600. In overstressed (*incompetent*) ground time-dependent squeezing will, in addition to the initial instability, take place. However, for this type of ground the support chart in Figure 5 needs updating when more experience in this type of ground can be made available.

## 4. SUPPORT CHARTS

The support charts in Figures 4 and 5 indicate the estimated amount and types of the total support. They are based on experience from several tunnels and other underground drill & blast excavations in Scandinavia. Figure 6 shows when these two charts should be used.

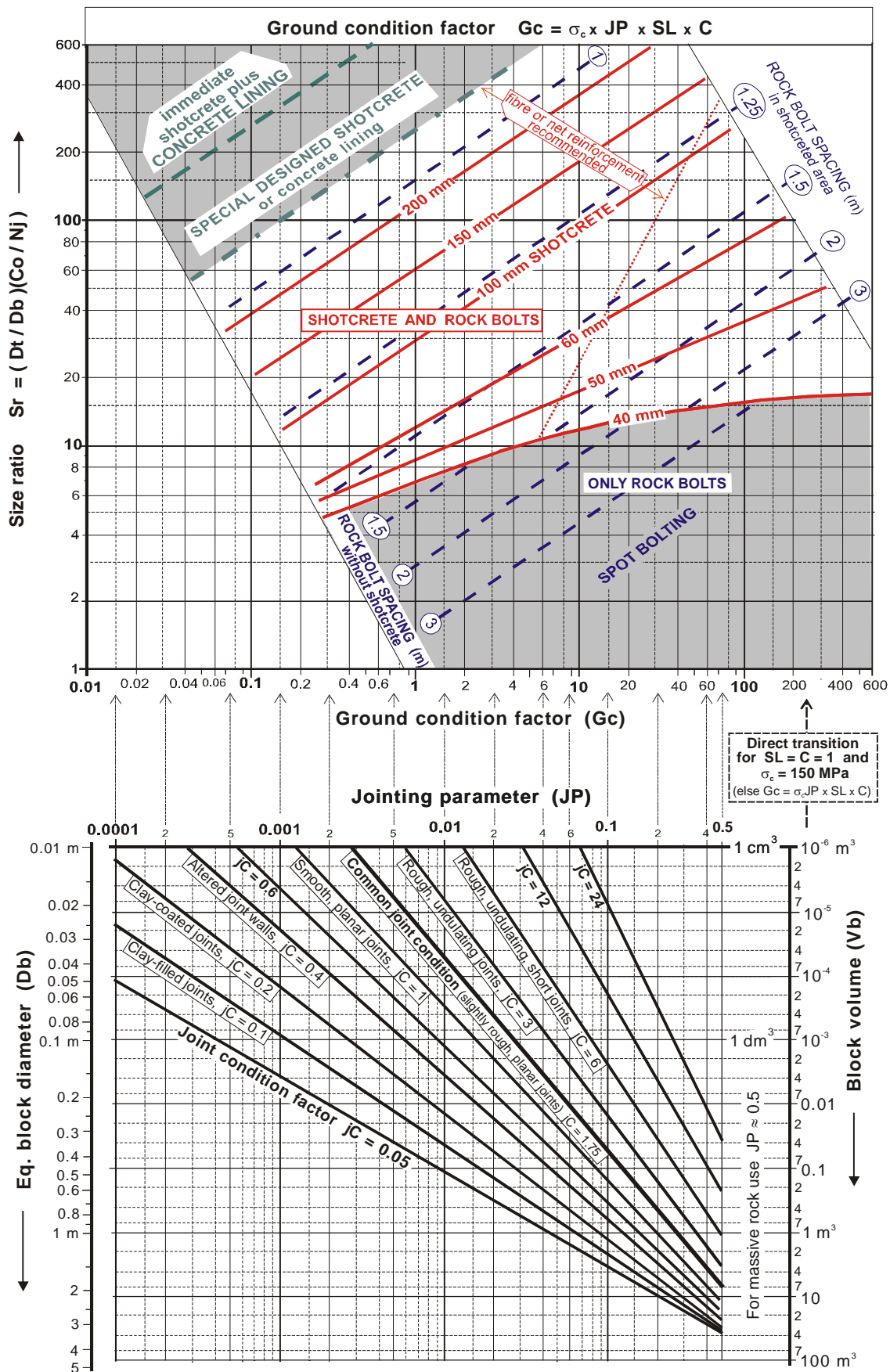

Figure 4 Upper chart: rock support for blocky ground including weakness zones. The ground condition factor ( $G_c$ ) for the roof can be found directly from JP when the compressive strength  $\sigma_c = 150$  MPa and the stress level ( $SL = 1$ ) are applied (Example: for  $V_b = 0.2$  m<sup>3</sup> and  $jC = 3$ ,  $G_c = 35$ ); Else  $G_c = \sigma_c \times JP \times SL \times C$  Lower chart: the jointing parameter (JP) found from  $V_b$  and  $jC$

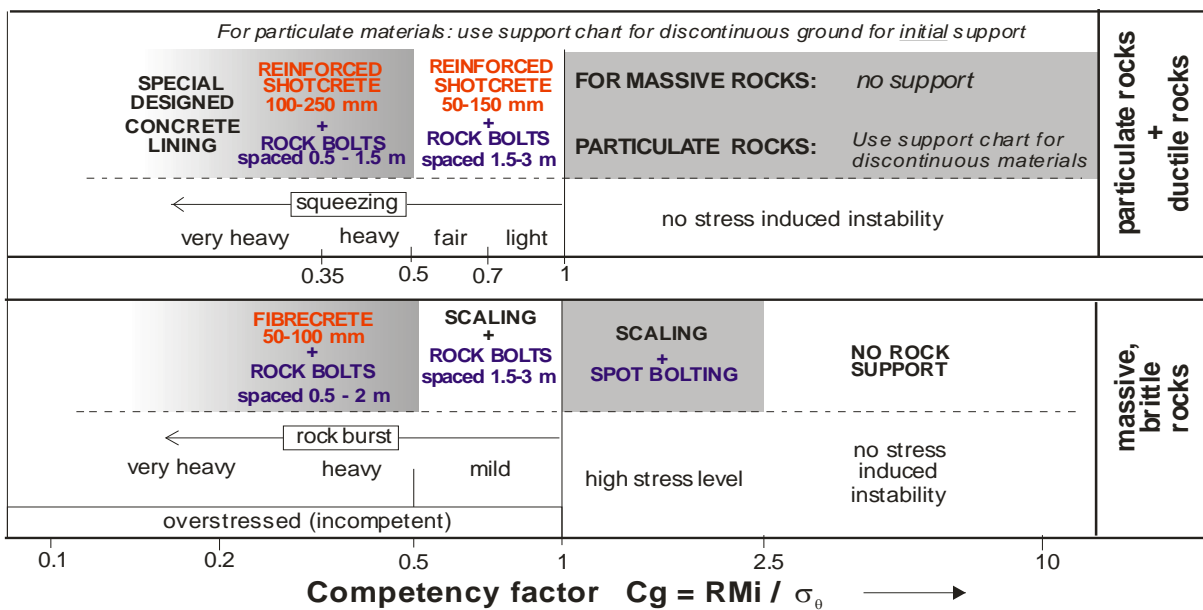

Figure 5 Chart for estimating support in continuous (massive and particulate) ground. Note that the support indicated for overstressed, particulate materials is approximate, as only a limited number of cases have been used

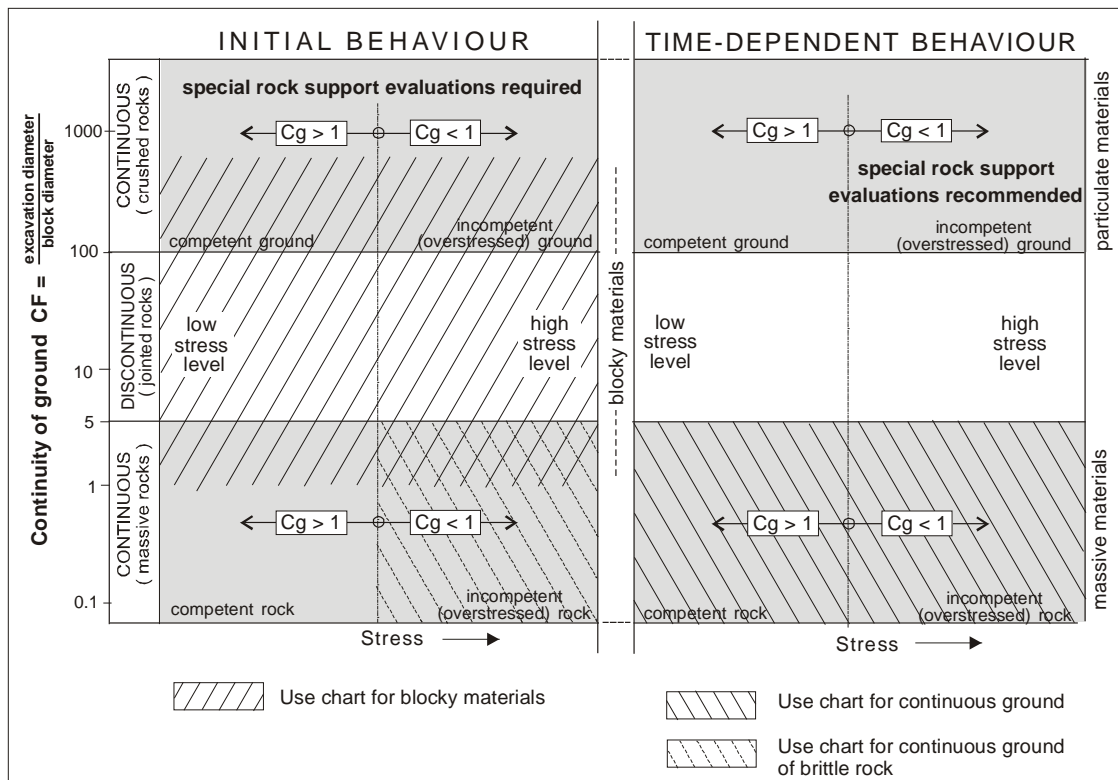

Figure 6 Recommended application of the two support charts, for blocky materials (Figure 4) and for continuous ground (Figure 5)

As shown in Section A5 in the Appendix, the calculation of Rmi and the support parameters applied in the charts can be quickly and easily made using a computer spreadsheet.

An understanding of the geological conditions at site is a must for a good characterisation of the rock mass and the ground conditions, and in selecting appropriate input values for the calculations. In this connection it should be noted that, being statistically based, a support chart can never accurately represent the ground conditions at site. The many variations in rock composition and properties as well as in geometry, density and structure of joints in a location makes characterization in a single or a few numbers very difficult. The



RMi support method includes, however, more parameters of the ground conditions and geometrical features at a site than most other classification systems for rock support, see Table 4.

For swelling and slaking rock the stability may be strongly influenced by local conditions. Therefore, the rock support should be evaluated separately for each of such cases. Other features to be separately assessed are connected to the local safety requirements, i.e. the required lifetime of the tunnel or cavern, and to the influence from vibrations caused by earthquakes or by nearby blasting, or by other impact from the activity of man.

## 5. EXAMPLES ON SUPPORT ESTIMATES

The examples are applied to a horse-shoe shaped tunnel with span  $Dt = 6$  m and wall height  $Wt = 5.5$  m

*General note:*

First, the type of ground should be determined from the ratio between tunnel size and block size. From this the appropriate method for support estimate is made. When only limited information on the ground conditions is available, the value of the joint condition factor is assumed  $jC = 1.75$  as for its most frequent occurrence. Similarly, the value of the adjustment factors  $SL = Co = Nj = 1$ . This is used in Examples 1 and 2. The estimates are for the tunnel roof for which the adjustment factor  $C = 1$ .

### Example 1 *Preliminary estimate (where very few input data are known)*

The tunnel is planned in a moderately jointed granite. What will the rock support be?

Evaluations:

- According to Table A2 in the Appendix the block volume in moderately jointed rock is:  $Vb = 0.03 - 1$  m<sup>3</sup> (average  $Vb = 0.5$  m<sup>3</sup>) with equivalent block diameter  $Db = \sqrt[3]{Vb} = 0.8$  m. The continuity factor  $CF = Dt / Db = 7.5$  which means that the ground is blocky, and equations eq. (4 - 7) can be used.
- From Table A1 the normal uniaxial compressive strength of granite is  $\sigma_c = 160$  MPa
- As described in Section 2 the most common joint condition is  $jC = 1.75$  for which eq. (1a) gives
- $RMi = \sigma_c \times JP = \sigma_c (0.26 \sqrt[3]{Vb}) = \sigma_c \times 0.21 = 33$  (The value of JP can also be found from the lower diagram in Figure 4)

Assuming unit value of the adjustment factors SL, Co and Nj, the support parameters in *roof* are:

- The ground condition factor:  $Gc = RMi \times SL \times C = 33$  (from eq. (4))
- The size ratio:  $Sr = (Dt / Db)(Co / Nj) = 7.5$  (from eq. (5))

Using these parameters in the support chart for blocky ground (Figure 4) the estimated roof support is: Rock bolts spaced 3 m. The wall support can be found in a similar way using  $C = 5$  in eq. (4) and the wall height  $Wt$  in eq. (5) instead of the span  $Dt$ .

### Example 2 *Preliminary support estimate for a weakness zone (few input data of the zone are known)*

It is assumed that the tunnel will encounter a  $Tz = 5$  m thick weakness zone, assumed to be a "coarse-fragmented crushed zone". What is probable rock support?

Evaluations:

From Table 3 the values  $RMi_z = 2$  and  $Db_z = 0.2$  are found for coarse-fragmented zones. With unit values of the adjustment parameters the *roof* support parameters are:

- $Gc = RMi_z \times SL \times C = 2$  (from eq. (4))
- $Sr = (Tz / Db_z)(Co_z / Nj_z) = 25$  (eq. (5) is applied because  $Tz < Dt$ )

From Figure 4 the following roof support in the zone is found: Rock bolts spaced 1.25 to 1.5 m and 80 mm thick shotcrete, fibre reinforced. The wall support can be found in a similar way using  $C = 5$  in eq. (4) and  $Wt$  instead of  $Dt$  in eq. (5).

**Example 3** *Rock support estimate during detailed design (where the values of input data are known)*

The tunnel will partly be located with 100 - 150 m overburden. From the field investigations performed, the following ground characteristics have been found representative for a section of the tunnel:

- The granite is fresh with compressive strength  $\sigma_c = 125$  MPa.
- The joints have the following characteristics: medium length, rough joint surfaces and undulating with fresh joint walls. This gives the following value of the joint condition factor
 
$$jC = jL \times jR / jA = 1 \times 3 / 1 = 3 \quad (\text{see eq. (3)})$$
- There are two joint sets plus random joints; the main joint set has strike =  $60^\circ$  and dip =  $45^\circ$  (relative to the tunnel axis), i.e. the orientation is *fair* both for the roof and the walls, see Table 2.
- The block volume varies mainly between  $0.5 \text{ m}^3$  and  $2.5 \text{ m}^3$ , average  $V_b = 1.5 \text{ m}^3$

Evaluations:

- With block diameter <sup>2</sup>  $Db = \sqrt[3]{V_b} = 1.14$  m, the continuity factor  $CF_{\text{roof}} = Dt / Db = 5.2$  (i.e. blocky ground)
- The following values of the adjustment factors are found from Table 2 using the information above:  $SL = 1$ ;  $N_j = 1.2$ ;  $Co_{\text{roof}} = Co_{\text{wall}} = 1.5$
- With input of  $jC = 3$  and  $V_b = 1.5 \text{ m}^3$  in Figure 4 (or using eq. (1)) the jointing parameter  $JP = 0.4$ ; and  $RMi = \sigma_c \times JP = 50$ .

From this the support parameters in roof are

- $G_c = RMi \times SL = 50$  (from eq. (4))
- $S_r = (Dt / Db)(Co / N_j) = 6.6$  (from eq. (5))

Estimated support in roof from Figure 4: Spot bolting or rock bolts spaced 2.5 m. Bolt length, according to eq. (13) given in the Appendix, should be  $L_b = 1.4 + 0.16Dt(1 + 0.1/Db) = 2.4$  m (or  $L_b$  can be found from Figure A2)

(In practise, the support parameters  $G_c$  and  $S_r$  should be calculated both for  $V_b = 0.3 \text{ m}^3$  and  $V_b = 3 \text{ m}^3$  and the support determined from that.)

**Example 4** *Support estimate for a weakness zone with known characteristics.*

During excavation of the tunnel at a depth of 150 m below surface, a  $T_z = 8$  m wide crushed zone has been encountered. It consists of slightly weathered granite with  $\sigma_c \approx 100$  MPa, the blocks in the zone have size  $V_b = 0.01 - 0.1 \text{ dm}^3$  (average  $V_b = 0.05 \text{ dm}^3 = 0.00005 \text{ m}^3$ ) with clay fillings in most of the joints. There are 4 joint sets in the zone mainly of short joints. The orientation of the zone is: strike =  $60^\circ$ , dip =  $25^\circ$  related to the axis of the tunnel.

Evaluations:

- From the description given the zone can be characterized as a clay-rich crushed zone. With average  $V_b = 0.00005 \text{ m}^3 (= 50 \text{ cm}^3)$  the block diameter  $Db = \sqrt[3]{V_b} = 0.04$  m.
- From Table 2 the following ratings are found:  $SL = 1$ ;  $N_j = 0.75$ ;  $Co_{\text{roof}} = 2$ ,  $Co_{\text{wall}} =$  (unfavourable zone orientation in roof and favourable for walls)
- The joint characteristics from Table 1 are:  $jL = 2$ ,  $jR = 1$  (nominal),  $jA = 10$ , which gives  $jC = jL \times jR / jA = 0.2$
- The jointing parameter  $JP = 0.00057$  is found from Figure 4 or eq. (1) and  $RMi = \sigma_c \times JP = 0.057$ .

From this the roof support parameters for blocky ground are:

- $G_c = RMi \times SL \times C = 0.057$  (from eq. (4))
- $S_r = (Dt / Db) (Co_z / N_{j_z}) = 400$  (as  $T_z > Dt$ , eq. (5) is used)

Using Figure 4, the roof support of the zone is: Shotcrete quickly applied after blasting and concrete lining. (In practise, the support parameters  $G_c$  and  $S_r$  should be calculated for the variation range of  $V_b$ )

<sup>2</sup>  $Db$  can also be found from the lower diagram in Figure 4

**Example 5** *Support estimate for massive, hard rock subjected to high rock stresses.*

A part of the tunnel is located in massive granite ( $\sigma_c = 130$  MPa) where the overburden is  $z = 1000$  m.

Evaluations:

- Massive rock means  $V_b = 8$  m<sup>3</sup> or larger. The block diameter is  $D_b = \sqrt[3]{V_b} = 2$  m (or larger). This gives  $CF = D_t / D_b = 3$  (or less), i.e., the ground is continuous.
- The magnitude of tangential stress around the tunnel is estimated using the method described in Section A3 in the Appendix:

Theoretical, vertical stress  $p_v = 0.027 \times z = 27$  MPa (eq. 15). From eq. (13) and assumed  $k = 1.5$  the tangential stress in the tunnel roof is  $\sigma_\theta = p_v (A \times k - 1) = 102.6$  MPa

In massive rock  $RM_i \approx 0.5 \sigma_c = 65$  (from eq. (2)), hence the competency of the ground is:

- $C_g = RM_i / \sigma_\theta = 65 / 102.6 = 0.63$  (from eq. (8))

According to Figure 5 the behaviour of the brittle granite is: Mild rock burst, which requires the following support: Rock bolts spaced 1.5 to 3 m.

## 6. DISCUSSION - CONCLUSION

This paper presents some simplifications in the RMi support method. One changes in the support parameters for weakness zones, making it easier to calculate the support parameters  $G_c$  and  $S_r$ .

Another simplification is the application of unit values for the adjustment factors in blocky ground if their values are not known as in preliminary support estimates. Some of the advantages achieved from this are:

- The sampling of input properties is strongly reduced, as only input of the block volume is needed (in addition to tunnel size).
- It leads to easier and quicker calculations of the support parameters.
- More accurate results can be achieved, when field investigations have been performed and real values of the input factors are used.

It is no direct correlation between the Q-system and the RMi support method. A main reason is that they partly use different input parameters (see Table 4) and that the principles in the support parameters and charts are different. In many of the cases where both the RMi support method and the Q-system have been applied, RMi method indicates more (stronger) support. A reason may be that the RMi support chart is developed later than the Q-chart and that it includes recent requirements for support.

An important feature in the RMi system is the use of the block volume as a main input. Another is that the two support parameters constitute real ground properties (rock mass strength and geometrical ratio). By this it is possible to understand the structure of the support method and the use of the input factors. The RMi requires, however, experienced users, which will reduce possible misuse.

Some of the *benefits* in the RMi support method are:

- The use of the three-dimensional block volume will generally improve the characterization of the rock mass and hence lead to better estimates, compared to the use of RQD and joint spacing applied in other support methods.
- In addition, the RMi support method includes all important ground parameters; more than other main classification systems used for rock support estimates, see Table 4.
- The use of different methods for support estimates in ground of different behaviour is reflected in different equations and calculations.

Table 4 The various parameters applied in the Q, RMi, and RMR rock support systems

PARAMETER		APPLICATION				
		in the Q system		in the RMi support method		in the RMR system
Rock	Rock strength	-		$\sigma_c$	uniaxial compressive strength	uniaxial compressive or point load strength
	Degree of jointing	RQD	rock quality designation	Vb	block volume	RQD joint spacing
Jointing	Joint sets (pattern)	Jn	joint set number	Nj	joint set factor	-
	Joint character	Jr	joint roughness number	jR	joint smoothness and waviness factor	joint roughness
	Joint coating or infilling	Ja	joint alteration number	jA	joint coating, filling and weathering factor	joint infilling, gouge joint weathering
	Joint size	-		jL	joint length and continuity	joint length, persistence
	Joint aperture	-	(partly in Ja)	-	(partly in jA)	joint separation
	Joint orientation	-		Co	joint orientation factor	orientation of joints
	Water	Ground water	Jw	joint water reduction factor	-	
Stress	Rock stresses	SRF	stress reduction factor	SL	stress level factor	-
Tunnel	Tunnel dimensions	Dt	span	Dt	span or diameter	-
		Wt	wall height	Wt	wall height	
		ESR	excavation support ratio			
GROUND	Rock mass strength	-		$RMi = 0.2 \sigma_c (jR \times jL / jA)^{0.5} \times Vb^D$ or $RMi = ca 0.5 \sigma_c$ (for massive rock)		-
	Ground competency	-		$Cg = RMi / \sigma_c$		-
	Ground quality (in roof)	$Q = RQD / Jn \times Jr / Ja \times Jw / SRF$		$Gc = RMi \times SL$		RMR = sum of the ratings for each factor above
	Ground quality (in wall)	$Q_{wall} = Q \times K$		$Gc_{wall} = RMi \times SL \times C$		
	Scale factor (in roof)	$De = Dt / ESR$		$Sr = (Dt / Vb^{1/3}) (Co / Nj)$		-
	Scale factor (in wall)	$De = Wt / ESR$		$Sr = (Wt / Vb^{1/3}) (Co / Nj)$		-
<p>K = adjustment of Q-value for walls. It varies with the Q-value;  C = adjustment factor for walls (and for all inclinations of the tunnel surface)  <math>D = 0.37 (jR \times jL / jA)^{-0.2}</math></p>						

Some of the *limitation* or problems in the RMi support method are:

- The RMi support method does not generally cover soil or soil-like materials, except where the material occurs in seams or small weakness zones with thickness less than a few metres.
- It is difficult to calculate the magnitude of tangential stresses in blocky ground, which in turn reduces the quality of the support assessments, especially to assess appropriate time-dependent rock support. (This is also the case for other methods for rock support in this type of ground.) More studies are needed to improve estimates here.
- The calculation of the parameters is more difficult than for the RMR and the Q systems as it involves exponential equations. However, from the diagrams in
- Figure the RMi value can easily be found. Using computer spreadsheet the various parameters needed for support estimates can be found directly, see Section A5 in the Appendix.

### Acknowledgement

The author wants to thank Prof. Håkan Stille at Royal Technical University (KTH), Stockholm, Prof. Björn Nilsen, Norwegian Technical University, and especially cand.scient. Olav Hval for valuable comments and suggestions during preparation of this paper.

## 7. LITERATURE

- Barton, N., Lien, R. and Lunde, J. (1974): "Engineering classification of rock masses for the design of rock support". *Rock Mechanics* 6, 1974, pp. 189-236.
- Bieniawski Z.T. (1989): "Engineering rock mass classifications". John Wiley & Sons, New York, 251 p.
- Cecil O.S. (1970): "Correlations of rock bolt - shotcrete support and rock quality parameters in Scandinavian tunnels". Ph.D. thesis Univ. of Illinois 1970.
- Deere D. and Miller R.D. (1966): "Engineering classification and index properties for intact rock". Univ. of Illinois, Tech. Rept. No. AFWL-TR-65-116, 1966.
- Hoek E. and Brown E.T. (1980): "Underground excavations in rock". Institution of Mining and Metallurgy, London 1980, 527 pp.
- Palmström, A. (1982): "The volumetric joint count - a useful and simple measure of the degree of jointing". Proc. IV Int. Congr. IAEG, New Delhi, 1982, pp V.221-V.228.
- Palmström A. and Berthelsen O. (1988): "The significance of weakness zones in rock tunnelling". Proc. Int. Conf. Rock Mechanics and Power Plants, Madrid 1988, 8 pp.
- Palmström, A. (1995): "RMi - a rock mass characterization system for rock engineering purposes". Ph.D. thesis, Univ. of Oslo, Norway, 400 pp.
- Palmström A. (1996): "Characterizing rock masses by the RMi for use in practical rock engineering".  
Part 1: Tunnelling and Underground Space Technology, Vol. 11, No. 2, pp. 175-186.  
Part 2: Vol. 11, No. 3, pp. 287-303.
- Piteau D.R. (1973): "Characterizing and extrapolating rock joint properties in engineering practice". *Rock Mechanics*, Suppl. 2, pp. 5-31.

## APPENDIX

### A1. Uniaxial compressive strength of intact rock

Where there are no test results of the uniaxial compressive strength ( $\sigma_c$ ) available, it may be estimated from strength tables. Table A1 shows values for some typical rocks.

Table A1 Average uniaxial compressive strength ( $\sigma_c$ ) of some rocks, measured on 50 mm samples

TYPE OF ROCK	$\sigma_c$	TYPE OF ROCK	$\sigma_c$	TYPE OF ROCK	$\sigma_c$	TYPE OF ROCK	$\sigma_c$
	MPa		MPa		MPa		MPa
Andesite (I)	140	Garnet micaschist (M)	<105>	Marble (M)	<130>	Shale (S)	95
Amphibolite (M)	<125>	Granite (I)	160	Micagneiss (M)	80	Siltstone (S)	<80>
Amphibolitic gneiss (M)	160	Granitic gneiss (M)	120	Micaquartzite (M)	85	Slate (M)	<190>
Augen gneiss (M)	160	Granodiorite (I)	105	Micaschist (M)	<80>	Syenite (I)	150
Basalt (I)	165	Granulite (M)	<150>	Mudstone (S)	95	Talcschist (M)	<65>
Claystone (S)	85	Gneiss (M)	130	Phyllite (M)	<50>	Tuff (S)	<25>
Diorite (I)	140	Greenschist (M)	<75>	Quartzite (M)	<145>	Ultraschist (I)	160
Dolerite (diabase) (I)	280	Greenstone (M)	170	Quartzitic phyllite (M)	100	Clay (hard)	0.7
Dolomite (S)	<100>	Greywacke (M)	120	Rhyolite (I)	85 (?)	Clay (stiff)	0.2
Gabbro (I)	240	Limestone (S)	100	Sandstone (S)	<120>	Clay (soft)	0.03
				Serpentinite (M)	135	Silt, sand (approx.)	0.0005

(I) = igneous, (M) = metamorphic, (S) = sedimentary rock; < > large variation

### A2. Measurements of the block volume (Vb)

The block volume (Vb) can be measured by different methods performed in the underground opening, on the surface, in rock cuttings, or in drill cores. Direct measurement can be made where the structure of the rock mass can be observed from measurements of joint spacings, from assessment of representative blocks at each observation point. The volumes will generally vary considerably at each site, and it is often a practice to measure the variation in volumes in addition to the average volume.

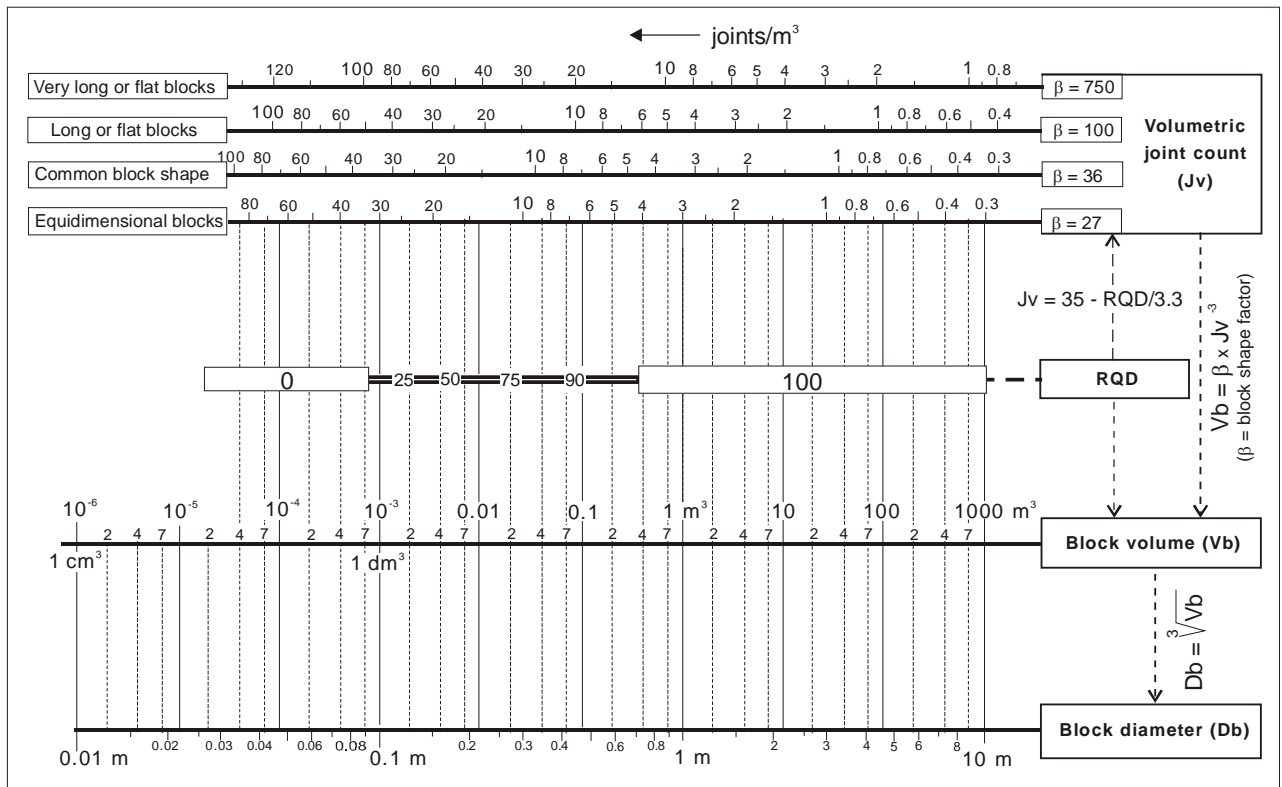

Figure A1 Connections between block size, block diameter and other jointing measurements.

Examples: For flat blocks with  $J_v = 5$  the block volume  $V_b \approx 0.7 \text{ m}^3$ . For equidimensional blocks with  $J_v = 5$  the block volume  $V_b \approx 0.2 \text{ m}^3$ . For  $RQD = 25$  the block volume  $V_b \approx 2 \text{ dm}^3$ .

Often, it is not possible to observe the whole individual block in an outcrop or in the surface of an underground opening, especially where less than three joint sets occur. Random joints or cracks formed during the excavation process will often result in defined blocks. In such cases a spacing of random joints 5 to 10 times the spacing of the main set can often be used to estimate the block volume.

*Example:* Where only one joint set (S1) can be seen,  $V_b \approx S1 \times 5S1 \times 10S1 = 50 S1^3$

For two joint sets (S1 and S2),  $V_b \approx S1 \times S2 \times 10S1 = 10 S1^2 \times S2$

Table A2 Classification of the degree of jointing

DEGREE OF JOINTING (or DENSITY OF JOINTS)	VOLUMETRIC JOINT COUNT		BLOCK VOLUME	
	TERM	J <sub>v</sub>	TERM	V <sub>b</sub>
Massive / no joints	Extremely low	< 0.3	Extremely large size	> 1000 m <sup>3</sup>
Massive / very weakly jointed	Very low	0.3 - 1	Very large size	30 - 1000 m <sup>3</sup>
Weakly jointed	Low	1 - 3	Large size	1 - 30 m <sup>3</sup>
Moderately jointed	Moderately high	3 - 10	Moderate size	0.03 - 1 m <sup>3</sup>
Strongly jointed	High	10 - 30	Small size	1 - 30 dm <sup>3</sup>
Very strongly jointed	Very high	30 - 100	Very small size	0,03 - 1 dm <sup>3</sup>
Crushed	Extremely high	> 100	Extremely small size	< 30 cm <sup>3</sup>

Correlation between block volume (V<sub>b</sub>) and volumetric joint count (J<sub>v</sub>):

- General expression  $V_b = \beta \times J_v^{-3}$  eq. (10)

- Expression for the most common block shape (where  $\beta = 36$ )  $V_b = 36 J_v^{-3}$  eq. (11)

Here  $\beta =$  the block shape factor, representing the jointing pattern.

It can be estimated from  $\beta \approx 20 + 7(S_{\max} / S_{\min})$  eq. (12)

(S<sub>max</sub> and S<sub>min</sub> are the longest and shortest dimension of the block)

### A3. A method to estimate of the tangential stresses around an underground opening

The magnitude of the tangential stresses ( $\sigma_\theta$ ) depends on the overall stress level, the stress anisotropy and the shape of the opening and can be found from rock stress measurements and Kirch's equations. Stresses around openings in massive rock or may also be estimated using the following simplified expressions presented by Hoek and Brown (1980):

- in roof:  $\sigma_\theta = p_v (A \times k - 1)$  (MPa) eq. (13)





- in walls:  $\sigma_\theta = p_v (B - k)$  (MPa) eq. (14)

Here  $k =$  horizontal stress/vertical stress

$p_v =$  the vertical stress in MPa at tunnel level, often found from  $p_v \approx 0.027 z$  [eq. (15)] ( $z =$  overburden in m)

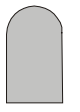
A and B are tunnel factors given in Table A3.

Table A3 Values of the tunnel shape factor

Tunnel factor	Tunnel shape				
					
A	4.0	3.2	3.1	3.0	1.9
B	1.5	2.3	2.7	3.0	1.9

**A4. Recommended length of rock bolts**

Suggested expressions for calculating the length of rock bolts from tunnel dimensions and the block size:

$$Lb_{\text{roof}} = 1.4 + 0.16 Dt (1 + 0.1 / Db) \quad \text{eq. (16)}$$

$$Lb_{\text{wall}} = 1.4 + 0.08 (Dt + 0.5Wt)(1 + 0.1 / Db) \quad \text{eq. (17)}$$

here Db = the block diameter in metre;  
 Dt = the tunnel span or diameter in metre;  
 Wt = the wall height in metre.

These equations are graphically solved in Figure A2

Note: The block diameter used should be given for the representative block size at the actual location.

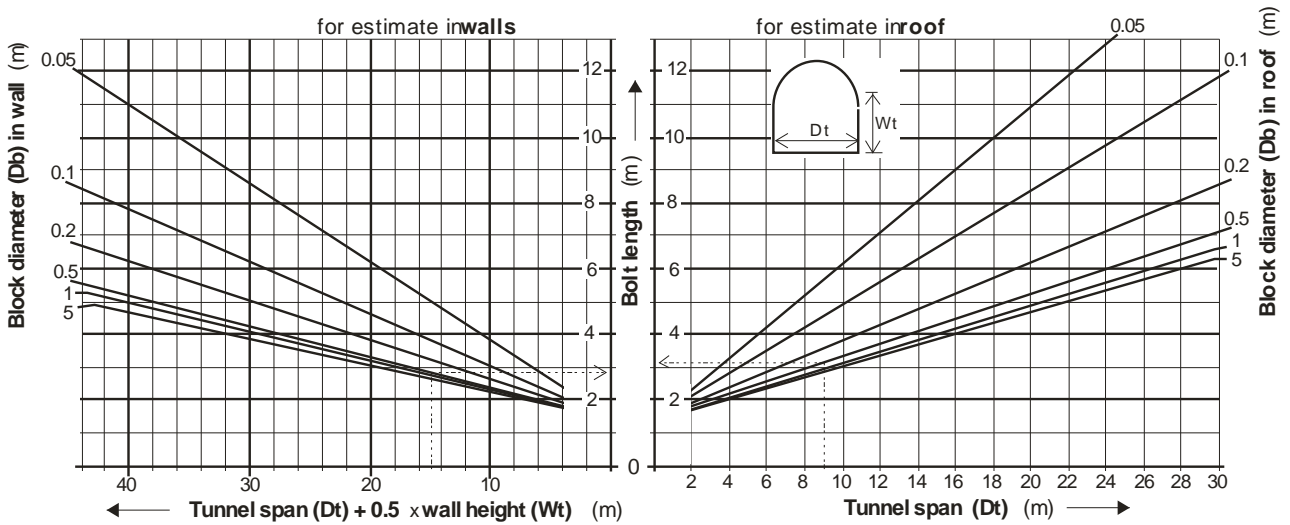

Figure A2 Bolt length determined from tunnel dimensions and block size.  
 Example shown: In a tunnel with 9 m span and 12 m wall height and average block diameter Db = 0.5 m, the bolt length will be 3.2 m in roof and 2.8 m in walls.

**A5. Description of a computer spreadsheet to calculate the value of the Rmi and the support parameters**

The Rmi system is well applicable for computer spreadsheets as all parameters involved have mathematical expressions and input of numerical values. Spreadsheets can be worked out using the flowchart in Figure 2 and the equations presented in this paper. Thus the value of Rmi as well as the parameters involved in the support system can very easily be found.

Table A3 shows a simple spreadsheet with calculation of the support parameters in the five 5 examples in Section 5.

Table A4 shows the expressions used for calculation in Table A3. You may work out your own spreadsheet from Table A4. Hints when making a spreadsheet:

Start to write in box A2 (with INPUT FACTORS ), then A3 (with Tunnel diameter or span (m) ) etc.

It is important that the expressions (in cells D20 to D31) are written correctly.



Table A3 The support parameters in Examples 1 – 5 are calculated in a spreadsheet (Excel).  
Required input factors both for blocky and for continuous ground are written in italic

		EXAMPLE 1	EXAMPLE 2	EXAMPLE 3	EXAMPLE 4	EXAMPLE 5
<b>INPUT FACTORS</b>		<i>values or ratings</i>				
	Symbol					
Tunnel diameter or span (m)	Dt	6	6	6	6	6
Tunnel wall height (m)	Wt	5.5	5.5	5.5	5.5	5.5
Compressive strength of intact rock (MPa)	$\sigma_c$	160	100	125	100	130
Joint roughness factor	jR	1.75	1	3	1	1.75
Joint alteration factor	jA	1	2	1	10	1
Joint length and termination factor	jL	1	1	1	2	1
Block volume ( m3 )	Vb	0.5	0.01	1.5	0.00005	8
Joint set factor	Nj	1	1	1.2	0.75	
Orientation factor of main joint set	- in roof	Co	1	1	1.5	1
	- in walls	Co	1	1	1.5	1
Orientation factor of weakness zone	- in roof	Co		1	1	2
	- in walls	Co		1	1	2
Thickness of weakness zone (m)	Tz		5		8	
Stress level factor	SL	1	1	1	1	
Tangential stress (MPa)	- in roof	$\sigma_\theta$				102.6
	- in walls	$\sigma_\theta$				
<b>CALCULATIONS OF:</b>		<i>results</i>				
Block diameter	Db	0.79	0.22	1.14	0.04	2.00
Joint condition factor	jC	1.75	0.5	3	0.2	1.75
Jointing parameter	JP	0.2104	0.0200	0.3907	0.0006	0.5264
Rock Mass index	RMi	33.657	1.997	48.843	0.057	65.000
Ground condition factor	- in roof	Gc	33.66	2.00	48.84	
	- in walls	Gc	168.29	9.99	244.21	
Size ratio	- in roof	Sr	7.6		6.6	
	- in walls	Sr	6.9		6.0	
Size ratio for weakness zone	- in roof	Sr		23.2		434.2
	- in walls	Sr		23.2		398.0
Competency factor	- in roof	Cg				0.634
	- in walls	Cg				

Table A4 Spreadsheet (Excel) showing the equations applied in Table A3. The input values in Example 1 have been inserted.

	A	B	C	D
1				EXAMPLE 1
2	<b>INPUT</b>			<i>values or ratings</i>
3	Tunnel diameter or span (m)		Dt	6
4	Tunnel wall height (m)		Wt	5.5
5	Compressive strength of intact rock (MPa)		$\sigma_c$	160
6	Joint roughness factor		jR	1.75
7	Joint alteration factor		jA	1
8	Joint length and termination factor		jL	1
9	Block volume ( m3 )		Vb	0.5
10	Joint set factor		Nj	1
11	Orientation factor of main joint set	- in roof	Co	1
12		- in walls	Co	1
13	Orientation factor of weakness zone	- in roof	Co	
14		- in walls	Co	
15	Thickness of weakness zone (m)		Tz	
16	Stress level factor		SL	1
17	Tangential stress (MPa)	- in roof	$\sigma_\theta$	
18		- in walls	$\sigma_\theta$	
19	<b>CALCULATIONS</b>			<i>results</i>
20	Block diameter		Db	=D9^0.3333
21	Joint condition factor		jC	=D6*D8/D7
22	Jointing parameter		JP	=0.2*(D21)^0.5*(D9)^(0.37*(D21)^-0.2)
23	Rock Mass index		RMi	=IF(D22<0.5,D22*D5,0.5*D5)
24	Ground condition factor	- in roof	Gc	=IF(OR(D10="",D11="",D12=""), "", D23*D16)
25		- in walls	Gc	=IF(D24="", "", 5*D24)
26	Size ratio	- in roof	Sr	=IF(OR(D24="",D15>0), "", D3/D20*D11/D10)
27		- in walls	Sr	=IF(OR(D24="",D15>0), "", D4/D20*D12/D10)
28	Size ratio for weakness zone	- in roof	Sr	=IF(D15>D3,D3/D20*D13/D10,IF(D15>0,D15/D20*D13/D10,""))
29		- in walls	Sr	=IF(D15>D4,D4/D20*D14/D10,IF(D15>0,D15/D20*D14/D10,""))
30	Competency factor	- in roof	Cg	=IF(D17="", "", D23/D17)
31		- in walls	Cg	=IF(D18="", "", D24/D18)